



High Pressure at Low Capacity

LKHM-110 Multi-Stage Centrifugal Pump

Application

LKHM-110 and -120/P is a highly efficient and economical multi-stage centrifugal pump, which meets the requirements of sanitary and gentle product treatment and chemical resistance. Both the LKHM-110 and LKHM-120P are available in 3 sizes, LKHM-112, -113, -114 and LKHM-122/P, -123/P, -124/P respectively, for 2, 3 and 4 stages.

Standard design

LKHM-110 and LKHM-120/P consist of a motor, stub shaft with key, mechanical compression coupling, adaptor, backplate, impellers, pump casing, intermediate casing (3 or 4 stage), pump cover, impeller screw and shaft seal.

The pumps are designed for CIP with emphasis on large internal radii and cleanable seals.

Shaft seals

The pumps can be fitted with two types of mechanical seals:

- Single internal seal.
- Flushed seal.

Both seal types have stationary seal rings of silicon carbide and rotating seal rings of carbon or silicon carbide.

The secondary seal of the flushed seal is a long lasting lip seal.

Materials

Product wetted steel parts Acid-resistant steel, AISI 316L and AISI 329L

Other steel parts: Stainless steel, AISI 304

Product wetted seals: EPDM.

Other O-rings: EPDM.

Finish: Polished $\leq 32Ra$ and 3A approved.

Technical data

Max. outlet pressure, LKHM-110/P, LKHM-120/P:

- Limited by the strength of the pump casing: 580 PSI (40 bar) temperature < 104° F.
- Limited by the strength of the pump casing: 290 PSI (20 bar) temperature > 104° F.

Temperature range: 14°F to +284 °F (EPDM).

Water pressure: Normally atmospheric, max. 15 PSI (flushed seal).

Water consumption: 0.066 -0.13 US GPM (flushed seal)

Noise level (at 3.3 ft: 60-80 dB (A).



LKHM-114

Versions

	LKHM-110	LKHM-110/P	LKHM-120/P
Inlet pressure	<145 PSI	>145 PSI	-
Motor	Standard	Special	Special
Back Plate	Standard	Reinforced	Standard
Shaft seal	C/SIC or SIC/SIC	SIC/SIC	SIC/SIC or SIC/C

Motor

Standard C-Face, foot mounted motor according to NEMA standard at 3500. Standard efficiency, insulation Class F.

Voltage and frequency

3 phase, 60 Hz, 230-460v standard. Other voltages and frequencies available upon request.

Hp

Horsepower requirements based on flow curves.

Dimensions (in)

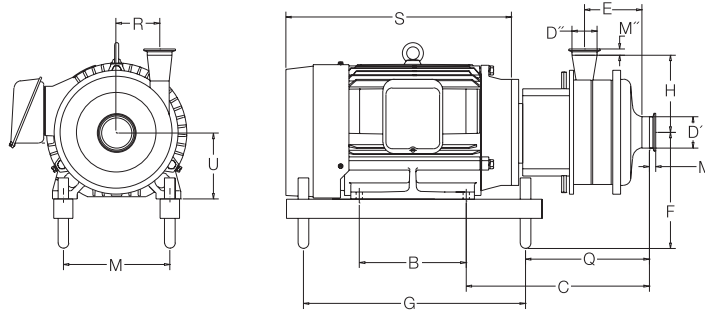

LKHM-112

Size	Motor			
	5 Hp	7.5 Hp	10 Hp	15 Hp
B	4.50	5.50	7.00	8.25
C	6.50	7.13	7.40	7.32
E	2.99	2.99	2.99	2.99
F	8.35	8.35	9.13	9.13
G	10.30	14.20	14.20	19.00
H	5.51	5.51	5.51	5.51
M	7.50	8.50	8.50	10.00
Q	8.86	10.87	11.14	12.64
R	3.39	3.39	3.39	3.39
S	12.00	14.60	16.10	18.70
U	5.83	5.83	6.61	6.61
Weight (lbs)	146.00	197.00	222.00	315.00

LKHM-113

Size	Motor		
	10 Hp	15 Hp	20 Hp
B	7.00	8.25	10.00
C	9.06	8.98	8.98
E	4.65	4.65	4.65
F	9.13	9.13	10.08
G	14.20	19.00	19.00
H	5.51	5.51	5.51
M	8.50	10.00	10.00
Q	12.80	14.29	14.29
R	3.39	3.39	3.39
S	16.10	18.70	19.40
U	6.61	6.61	7.56
Weight (lbs)	238.00	331.00	381.00

LKHM-114

Size	Motor			
	15 Hp	20 Hp	25 Hp	30 Hp
B	8.25	10.00	9.50	11.00
C	10.59	10.59	11.77	11.77
E	6.26	6.26	6.26	6.26
F	9.13	10.08	10.83	10.83
G	19.00	19.00	20.00	20.00
H	5.51	5.51	5.51	5.51
M	10.00	10.00	11.00	11.00
Q	12.64	12.64	14.49	14.49
R	3.39	3.39	3.39	3.39
S	18.70	19.40	23.90	23.90
U	6.61	7.56	8.35	8.35
Weight (lbs)	347.00	397.00	478.00	509.00

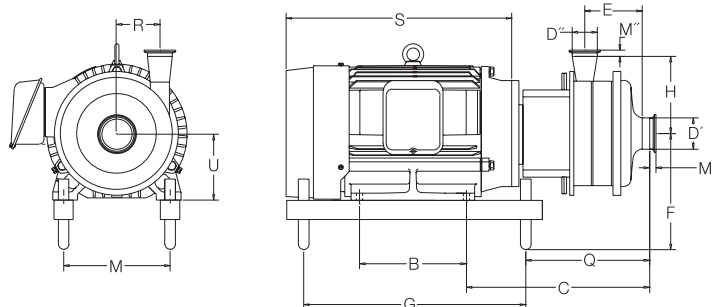

LKHM-122/P

(in)	Sterling-motor	
	hp	
	40/50/60	
A	9.69	
B	12.01	
C	16.18	
E	3.27	
F min.	10.24	
F max.	15.16	
G	21.02	
H	10.43	
K	26.5	
M	12.52	
P min.	26.02	
P max.	30.94	
Q	10.16	
R	4.45	
S	27.56	
T	7.87	
U	8.66	
Z min.	23.03	
Z max.	27.95	
Weight (lbs)	816/816/860	

LKHM-124/P

	Sterling-motor	
	hp	
	40/50/60	75/100
A	9.69	15.31
B	12.01	12.2/13.7
C	14.65	16.69
E	7.76	7.76
F min.	10.24	15.79
F max.	15.16	18.19
G	21.02	25.2
H	10.43	10.43
J	12.52	15.98
K	26.5	29.65
P min.	26.02	31.93
P max.	30.94	34.33
Q	20.67	24.33
R	4.45	4.45
S	27.56	33/35
T	7.87	9.8
U	8.66	
Z min.	23.03	29.4/30.6
Z max.	27.95	31.8/33
Weight (lbs)	891/891/935	1274/1307

LKHM-123/P

(in)	Sterling-motor	
	hp	
	40/50/60	75/100
A	9.69	15.31
B	12.01	12.2/13.7
C	18.46	16.69
E	5.55	7.76
F min.	10.24	15.79
F max.	15.16	18.19
G	21.02	25.2
H	10.43	10.43
K	26.5	15.98
M	12.52	29.65
P min.	26.02	31.93
P max.	30.94	34.33
Q	12.44	24.33
R	4.45	4.45
S	27.56	33/35
T	7.87	9.8
U	8.66	
Z min.	23.03	29.4/30.6
Z max.	27.95	31.8/33
Weight (lbs)	853/853/897	1274/1307

Connections (in)

LKHM-112, LKHM-113, LKHM-114

DI 2"	Tri-Clamp
DII 1½"	
M I	0.827
M II	0.827

Volumetric Flow

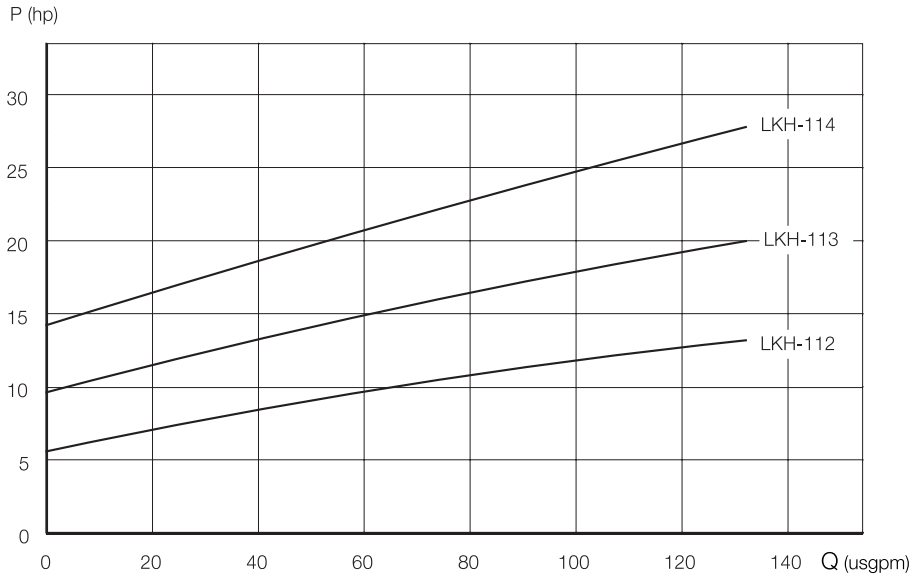
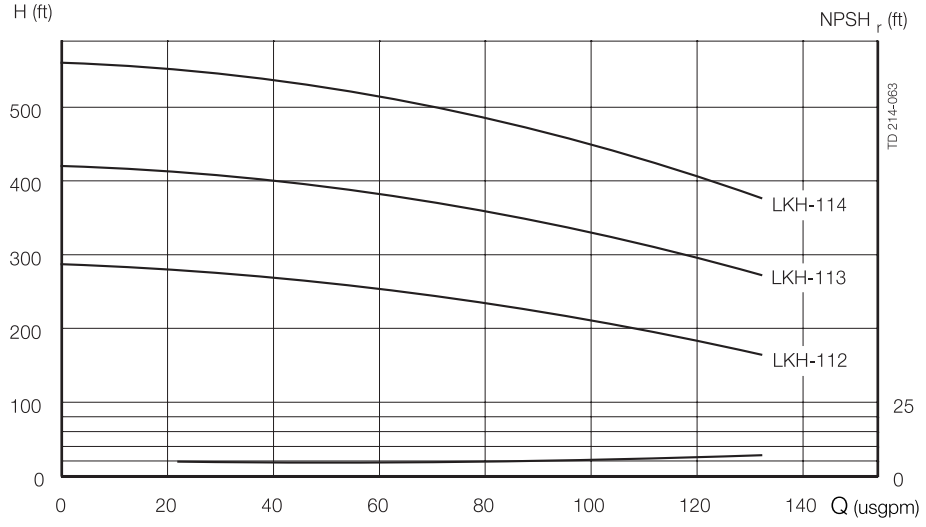

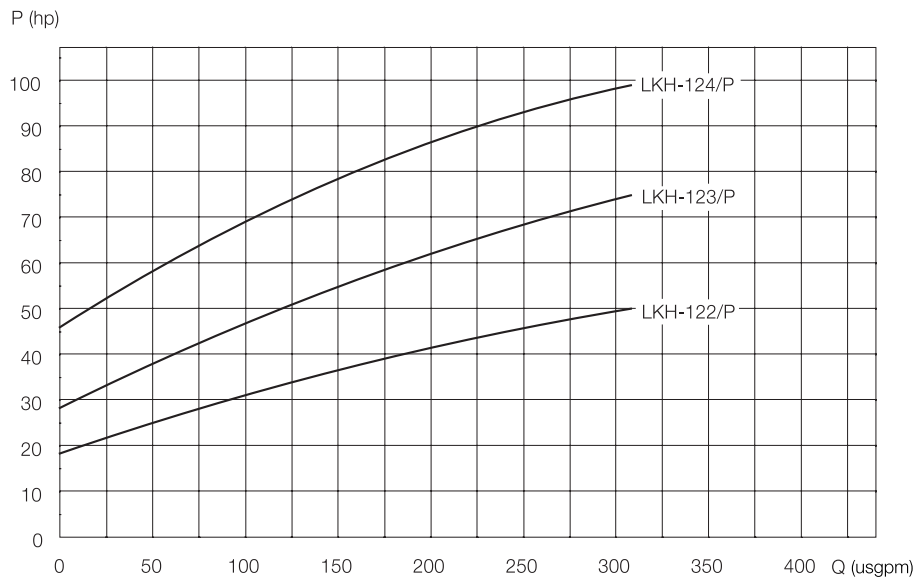
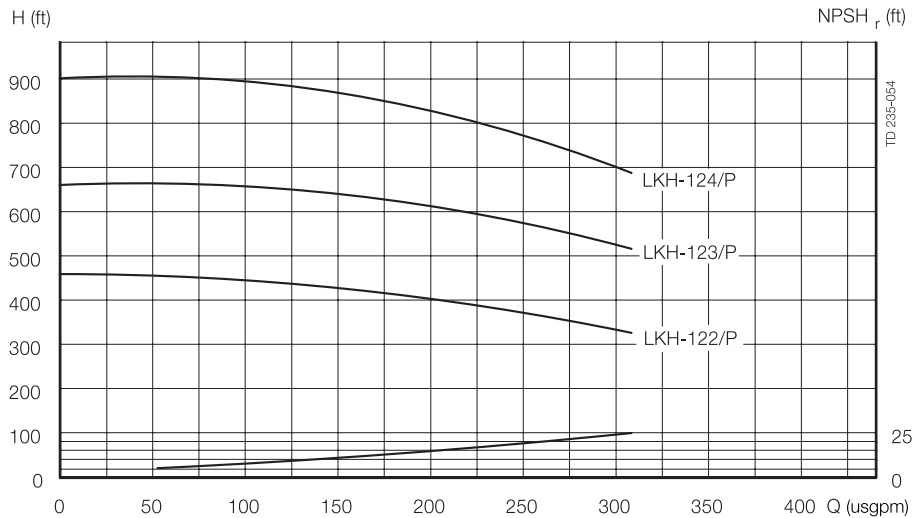

Options Equipment

- Special motor for inlet pressure higher than 10 bar.
- Motor for other voltage and/or frequency
- Flushed shaft seal.
- Impeller with reduced diameter.
- Counter flanges, seal rings and bolts for flanged connections (industrial version).

Material grades

- Product wetted seals of Buna (NBR), or Fluorinated rubber (FPM).
- Rotating seal ring material in Silicon Carbide.
- surface roughness, product wetted parts: unpolished, 32Ra, micro inches (0.8 mm), or higher finishes

Ordering

Please state the following when ordering:

- If the inlet pressure is higher than 145 PSI it is necessary to order a special version with a modified motor and a stronger backplate. Use the following designation:
 - LKHM-110: Inlet pressure (0-145 PSI)
 - LKHM-110/P: Inlet pressure > 145 PSI
- Pump size.
- Version, sanitary or industrial.
- Connections.
- Impeller diameter.
- Motor size.
- Voltage and frequency.
- Flow, pressure and temperature.
- Density and viscosity of the product.
- Options.

ESE00266ENUS 0705

The information contained herein is correct at the time of issue, but may be subject to change without prior notice.

How to contact Alfa Laval

Contact details for all countries are continually updated on our website. Please visit www.alfalaval.com to access the information direct.