



FLOW  
LEVEL  
PRESSURE  
ANALYTICAL  
TEMPERATURE  
INSTRUMENTATION  
PASTEURIZATION CONTROLS

**omd** 800-648-3326  
oliver m. dean, inc. www.omdean.com

## "HT" Optical Transition Sensor

- *Provides 4-20mA output for detecting transitions in continuous fluid processing systems*
  - *significant reduction in BOD charges*
  - *enhanced efficiency through automation*
  - *greatly reduced product losses*
- *Compact, single sensor with sapphire lens for ease of integration into existing systems*
- *Stainless steel construction, with NEMA 4X rating*
- *3-A compliant; Third party verified in accordance with standard 46-03*

Anderson's HT Optical Transition Sensor is a compact sensor used to identify product changeovers in sanitary lines by providing a linear 4-20mA output proportional to the concentration of solids or fat molecules in a flowing stream of product. This in turn allows for automation of applications involving milk, ice cream, whey, juice or beer.

At the heart of the "HT" sensor is a small, robust, corrosion-resistant sapphire lens. The lens incorporates a silicone seal to meet 3-A

standards for cleanability and sterility.

The "HT" can be easily integrated as an input to a PLC or a simple display with switching or alarm capability. The transmitter is available in four tri-clamp sizes for ease of mounting to any sanitary line. Each unit is provided with a pre-wired, water-tight, quick-disconnect receptacle, and mating connectors with sealed cables are available as an option.

This simple, inexpensive sensor can pay for itself in a

matter of weeks by providing real-time data for optimizing product changeovers, or for detecting actual product-to-water or water-to-product transitions. It has been proven to significantly reduce Biological Oxygen Demand (BOD) loading in effluent streams while protecting against product adulteration.

Detailed specifications and ordering information can be found on the reverse, or by visiting our website at [www.andinst.com](http://www.andinst.com).

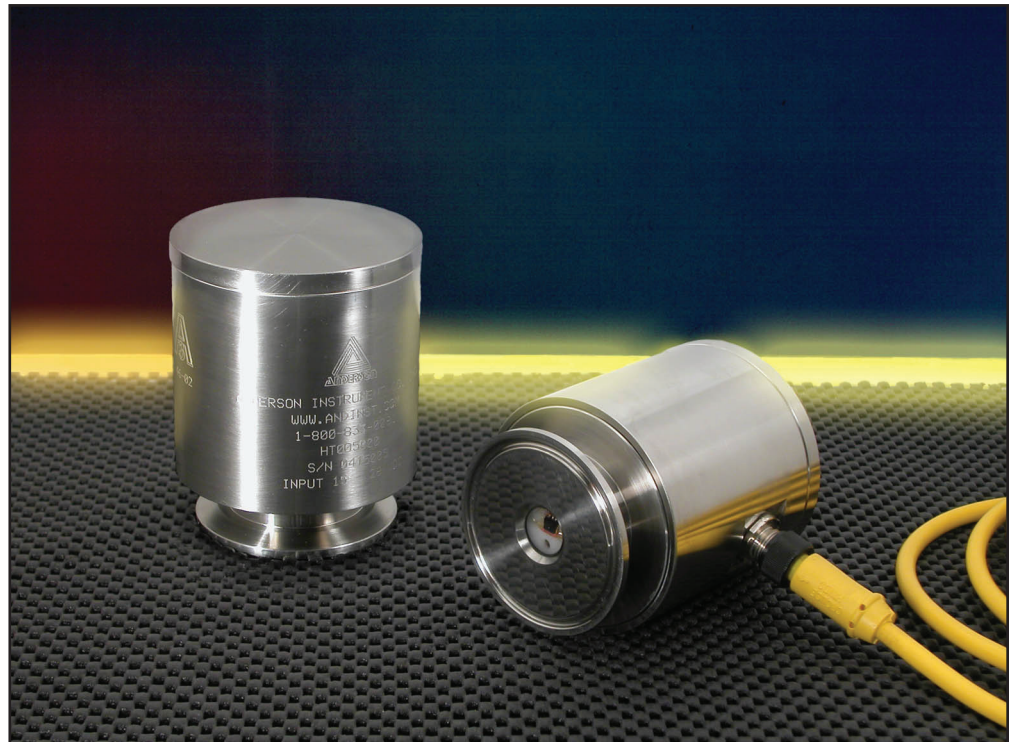

# HT Specifications

## Performance/Electrical

Accuracy:	± 0.2% of span at 4.00mA (Water)
Repeatability:	± 1.0% of span in any target fluid
Response Time:	10 milliseconds
Resolution:	0.10% of reading with typical calibration
Process Temp. Range:	32° to 250°F (continuous)
Ambient Temp. Range:	40° to 120°F
Process Temp. Shock:	Withstands instantaneous changes of up to 125° (e.g. From 40° to 165°F during CIP, or from 125° to 250°F during SIP)
Temperature Effect:	0.9% of span/10°F change (process and/or ambient) max.
Process Temperature Limits:	Vacuum to 200psig at rated temp.
Output:	4-20mA, 3 or 4 wire
Power:	15-28 Vdc, at 35mA
Connection:	5-pin, water-tight, with quick-disconnect cabling

## Mechanical

Housing Material:	316-series stainless steel
Dimensions:	3.0" diameter x 3.6" length (approx.) (see sketch below)
Weight:	4lbs. (approx.)
Ratings:	NEMA 4X (water-tight, corrosion proof) Authorized to carry 3-A Symbol (Standard 46-03)
Fitting:	316-series stainless steel; R <sub>a</sub> = 32 microinches (.8 microns)
Optical Lens:	Uncoated, optical sapphire (aluminum oxide) minimum thickness = 2.3 mm
Lens Seal:	60 durometer, FDA approved silicone rubber (meets ZZR-765-E, Class-2 A and B)

## HOW TO ORDER



### FITTING

- 004 1.5" Tri-Clamp®
- 005 2" Tri-Clamp®
- 006 2.5" Tri-Clamp®
- 007 3" Tri-Clamp®

### CABLE LENGTH

- 00 Quick Disconnect Receptacle (QDR) w/No Cable, no FWC
- 01 QDR & Field Wireable Connector (FWC) w/No Cable (std.)
- 05 QDR & FWC w/25 ft Cable
- 10 QDR & FWC w/50 ft Cable
- 15 QDR & FWC w/75 ft Cable
- 20 QDR & FWC w/100 ft Cable
- 25 QDR & FWC w/125 ft Cable
- 30 QDR & FWC w/150 ft Cable

### FIXED CHARACTER

### NOTE:

All sensors are factory calibrated to a range that covers from Water (4.00mA) to a Pure White Standard (20.00mA). Typical Dairy products such as Skim Milk, 1% Milk, 2% Milk, Whole Milk and Cream fall within this range. Unit may be field calibrated for products having solids content outside this range. Complete instructions for recalibration are included in the manual (DOC 1118).

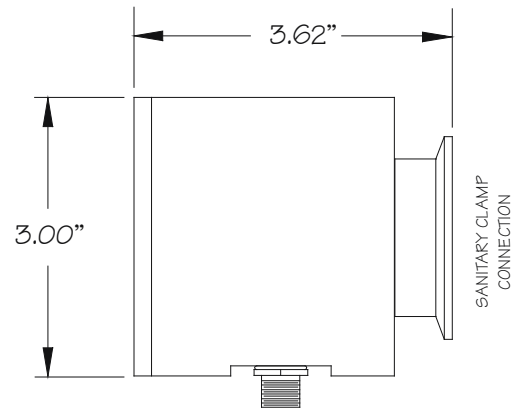

Typical HT Response with Fluid Milk Products

