



FLOW
LEVEL
PRESSURE
ANALYTICAL
TEMPERATURE
INSTRUMENTATION
PASTEURIZATION CONTROLS

omd 800-648-3326
oliver m. dean, inc. www.omdean.com

Vat Pasteurization - Electronic Controls Package

- All electronic components, without mercury in glass thermometers
- Digital displays easier to read than thermometer scales
- All stainless steel probes provide rugged reliability in harsh conditions
- Circular chart recorder uses 12" chart for maximum readability
- Nema 4X case withstands demands of wash down environment
- Complete package compliant with P.M.O. requirements; 3-A Sanitary Standards

In today's Dairy industry, vat pasteurization continues to be a commonly used process. Traditional controls use mercury in glass thermometers for the airspace and product references. As leaders in the sanitary marketplace, Anderson is proud to offer an all electronic controls package. Production plants utilizing vat pasteurization, along with small farmstead operations, no longer need to worry about dealing with hazardous materials.

First and foremost, this package consists of a dual pen circular chart recorder. The time proven AJ-300 series recorder is provided. This unit offers NEMA 4X wash-down protection in an enclosure that is easily wall or panel mounted. Front mounted displays provide convenience to the operator for monitoring the process.

Next, two dual element all stainless steel temperature probes are provided. One probe is used for monitoring airspace temperature, and the other for monitoring product temperature. Each probe has an integral display, easily viewable by the operator. It is this display that replaces the

traditional mercury in glass thermometer. One temperature element of each of the probes directly wires to the AJ recorder. This provides recording for the hot product, recorder pen one, and the airspace, recorder pen two. The remaining temperature element of each probe provides a signal directly to the integral display. This display functions as the airspace and product reference temperatures in each of the respective probes.

As in the traditional process, the operator simply views the temperature from the display on each of the probes, and matches to the recording trace on the recorder. As the temperatures on the reference probes are now digital, difficulty in reading mercury in glass thermometer scales is also eliminated.

Safety, accuracy and reliability; all in a simple to operate package.

Complete specifications and ordering information are available inside. For more information please visit our Web Site at www.andinst.com, or contact your local Authorized Anderson Distributor.



System Drawing

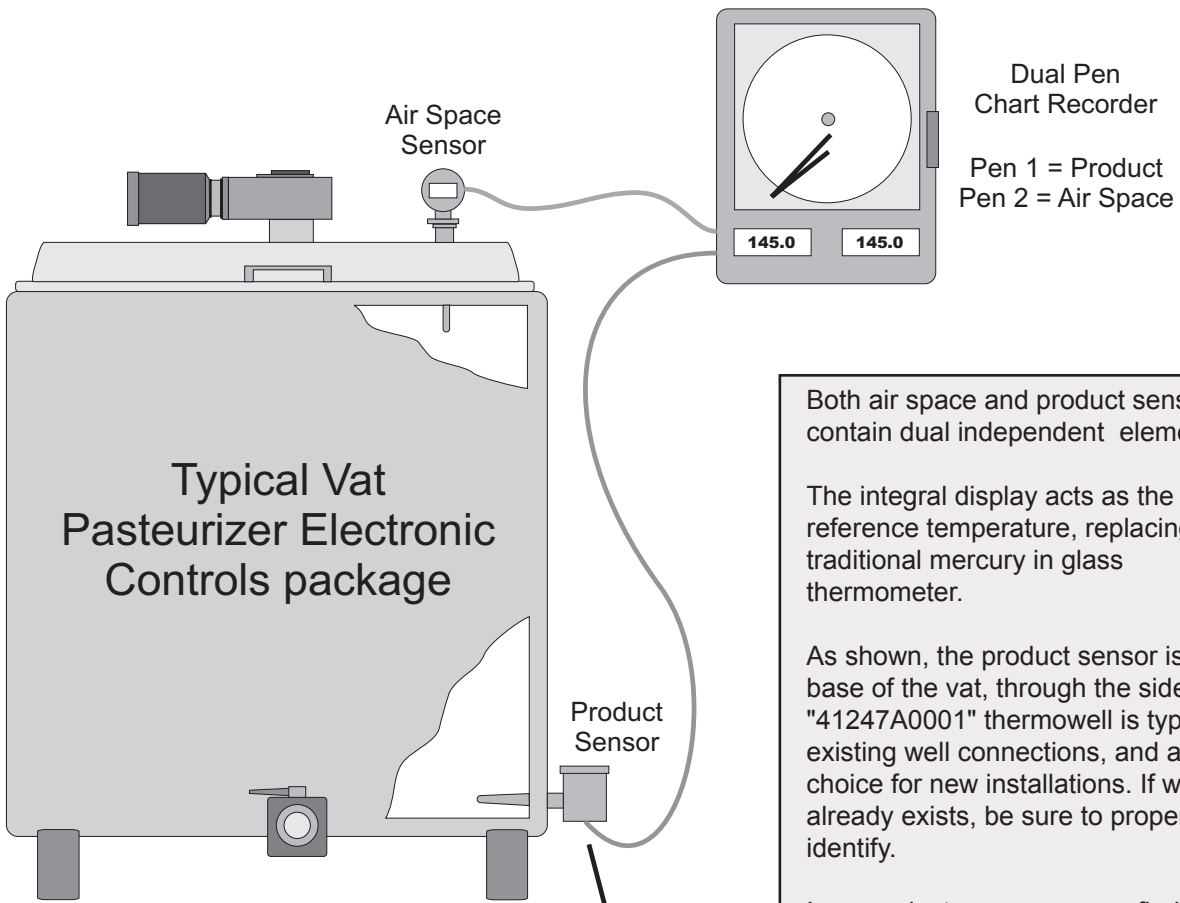

Both air space and product sensors contain dual independent elements.

The integral display acts as the reference temperature, replacing a traditional mercury in glass thermometer.

As shown, the product sensor is at the base of the vat, through the side wall. A "41247A0001" thermowell is typical for existing well connections, and a good choice for new installations. If well already exists, be sure to properly identify.

In many instances you may find a "top" mounted installation of the product sensor. Top mounts typically utilize an Umbrella style fitting, or a Clamp style fitting.

Internal View
Air Space
and
Product Sensor

Dual Element Sensor
(SA Series)

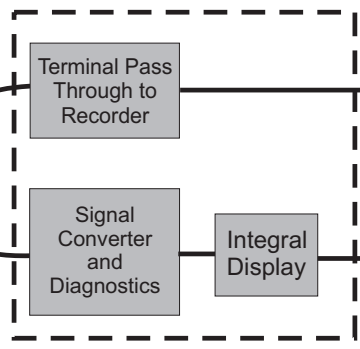

Temperature
Signal
Direct To
Recorder

Power ONLY
from Recorder
to Display

Wiring Head
(CT Series)

Circular Chart Recorder Ordering Matrix

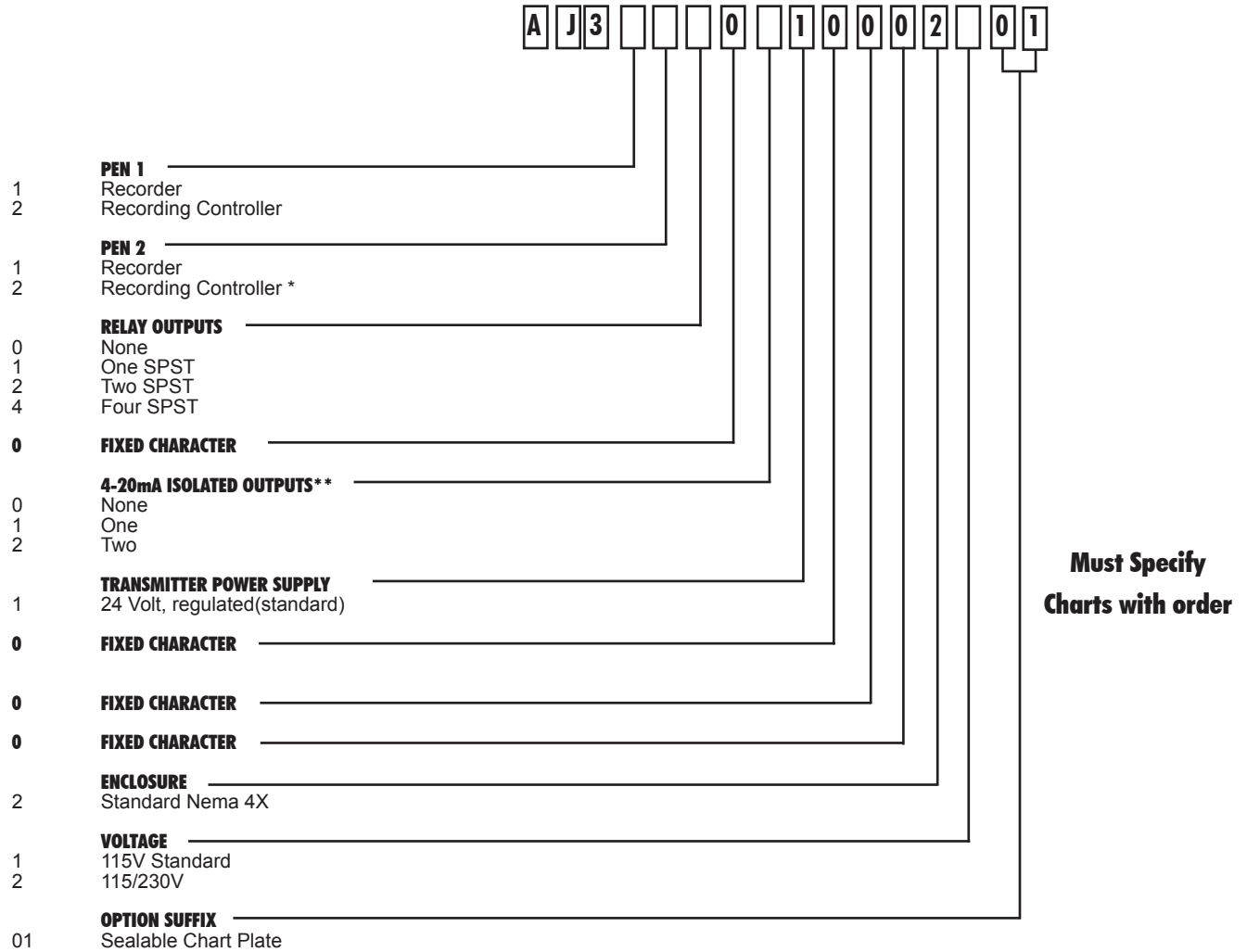

* Pen 2 available as Recording Controller, only if Pen 1 is Recording Controller.
 ** Required for each controller, if modulated output is required.

CHARTS

00215307	90-190 12hr (Std °F range)
00215303	0-200 24hr (If pasteurization is above 160°F)
00215357	30-90 12hr (Std °C range)

PENS

60500402	(Red, Pen #1)
60500401	(Green, Pen #2)

Sanitary Projectile Well

PART #	DESCRIPTION
41247A0001	Weld-in Sanitary Projectile Well

NOTE: For new installations, the sanitary well 41247A0001 is typically installed into the side wall of the vessel. This well will then hold the product sensor.

Sensor Wiring Head Ordering Matrix

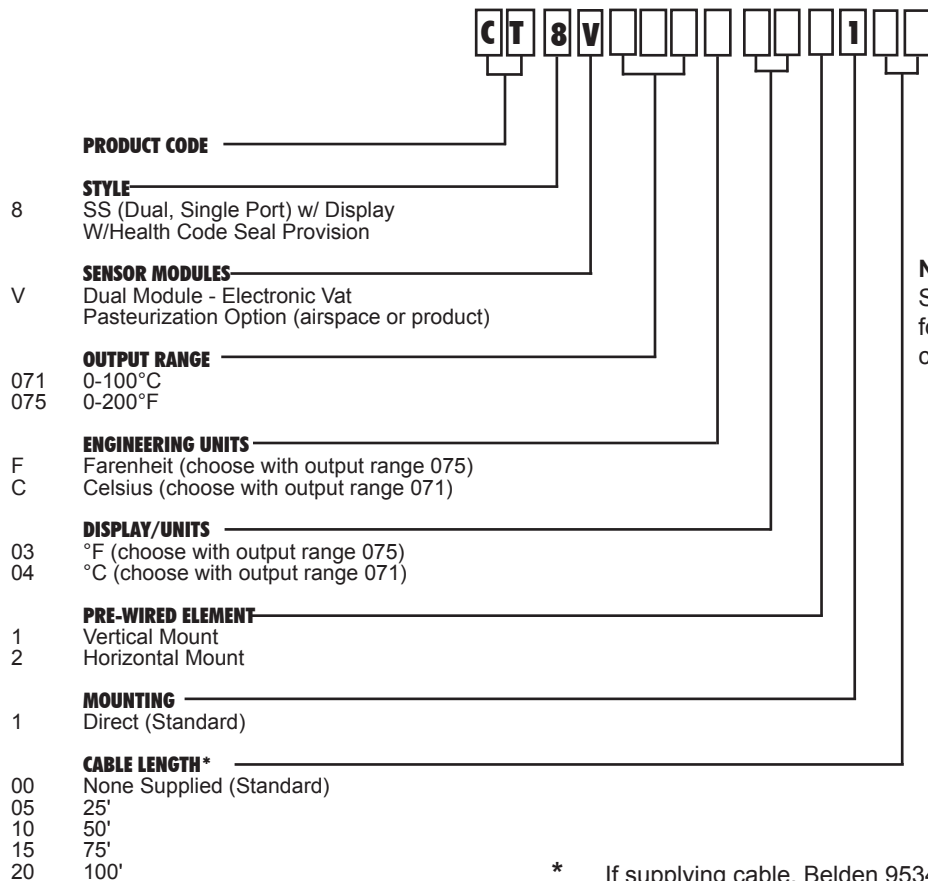

NOTE:
Specify CT/SA combo
for airspace, and CT/SA
combo for product

* If supplying cable, Belden 9534 or
equivalent (4 wire w/ continuous drain)

RTD Temperature Element Ordering Matrix

