

# SONDERMANN

PUMPEN + FILTER GMBH & Co. KG



Absolutely safe to run dry



RM-TS, the first magnetically coupled centrifugal pump without any sleeve bearing in the world that is absolutely safe to run dry.

**omd** ■ 800-648-3326  
oliver m. dean, inc. ■ [www.omdean.com](http://www.omdean.com)

SONDERMANN  
Competence in pump  
and filter technology

# This pump revolutionizes all magnetic coupling technology!

## SONDERMANN RM-TS the new type of pumps safe to run dry:

Conventional magnetically coupled pumps are not designed for dry run situations. In fact, sleeve bearings used in such high-speed systems need continuous liquid-film lubrication to keep bearing friction and the resulting frictional heat as low as possible and also to provide the bearing with sufficient cooling.

SONDERMANN presents a totally new type of magnetically coupled centrifugal pump that works without any sleeve bearing.

The coefficient of friction of the new type of bearing that has been used for the first time with magnetically coupled centrifugal pumps is so low, that only a minimum of heat is generated. Therefore, the bearing does not require any cooling or liquid lubrication.

The new pump includes all advantages of our longstanding experience with pumps of the RM type and the additional certainty that they will not be damaged by dry running:

All components of the pump head that are in contact with the fluid, are still metal-free, this is to assure optimum chemical resistance against aggressive fluids.

Since the pump does not have a shaft seal, it is hermetically separated and because of this unique design, leakages through worn shaft sealings are definitely ruled out.

### **Other producers refer their pumps to as being:**

- ▶ capable to run dry,
- ▶ extremely capable to run dry,
- ▶ suitable to run dry,
- ▶ partly suitable to run dry.

### **We guarantee:**

- ▶ magnetically coupled centrifugal pumps which are absolutely safe to run dry.

**Patent is filed**



## Characteristic curves of RM-TS pumps

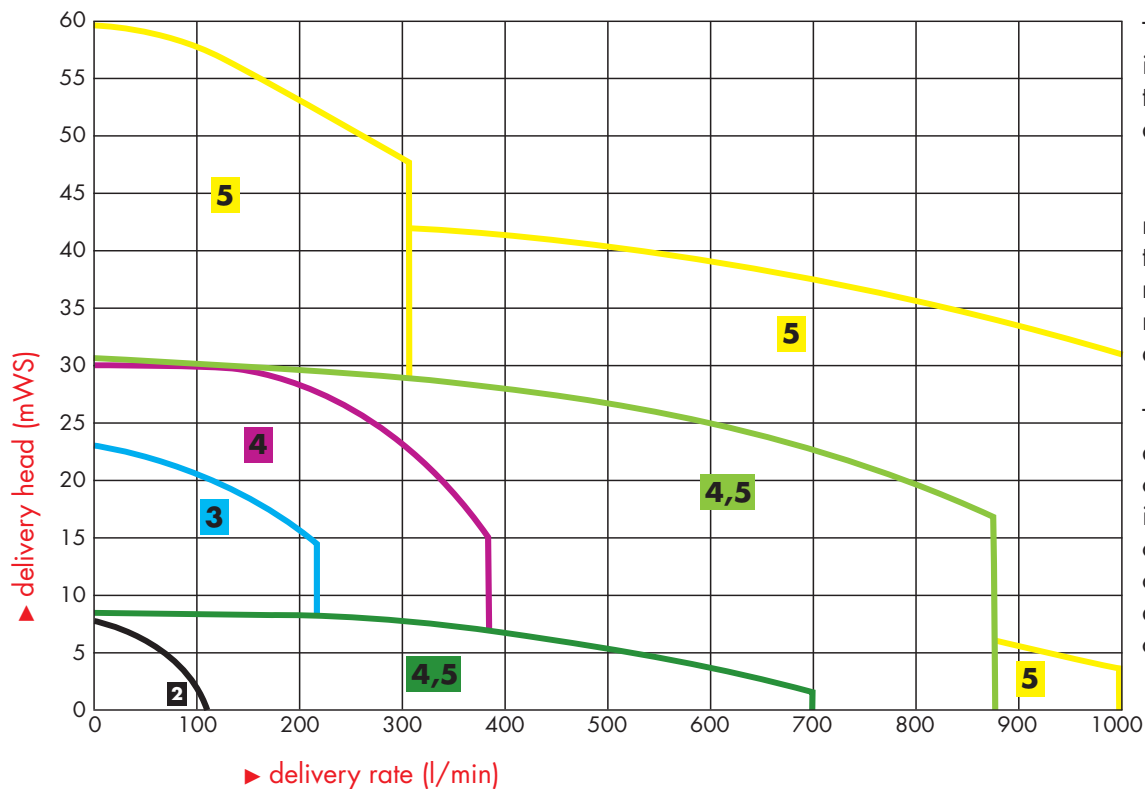

The RM-TS series includes pumps from the RM2-TS type with a delivery rate of 110l per minute, 10 mwc and a 90 W motor to the RM5-TS type with a delivery rate of 1,500l per minute, 60m wc and a 15 kW motor.

Technical data and dimensioned drawings of RM-TS pumps are identical with those of standard types of RM pumps. For details, see our main catalogue.

### Simple and reliable design

- ▶ No liquid cooled sleeve bearings.
- ▶ Increased efficiency by using bearings with an extremely small coefficient of friction.
- ▶ Extremely high resistance to chemicals.
- ▶ All present pumps of the RM-type can be adapted, upon request, to this new system to become absolutely safe to run dry.
- ▶ Also for high speed operation.

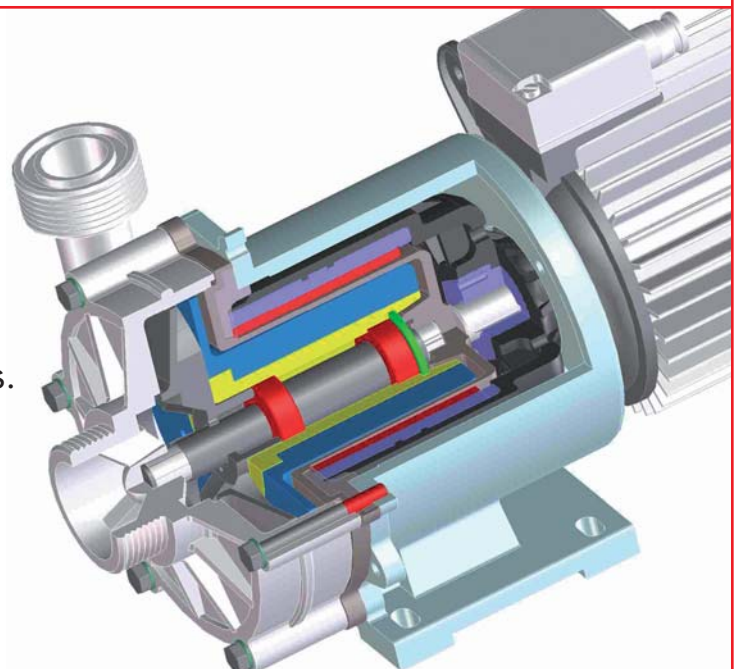

## Typical examples of dry-running conditions in practice and their impact on „normal standard“ and on RM-TS pumps:

Dry-running conditions	Impact on magnetically coupled centrifugal pumps of „normal standard“ design	Impact on the new RM-TS pumps safe to run dry
A mechanic checks the sense of rotation of the pump although there is no fluid in the pump housing.	Depending on the size of the pump and how long the check takes (some minutes), the pumps are often already defective or broken down when being installed.	NONE!!! As soon as the pump is filled with fluid, it works without being damaged.
When the pump is started, the valve in the suction line is still closed.	Depending on the size of the pump and how long the valve remains closed, the pumps are often defective or even broken down.	NONE!!! As soon as the valve is open, the pump works without being damaged.
The suction line tank runs dry and the level controller is defective or not available. The pump runs dry until the operating personnel realises that the tank is empty.	Depending on the size of the pump and how long it runs dry, it will be damaged sooner or later.	NONE!!! As soon as the pump is filled with fluid, it continues to work without being damaged.
Suction and pressure lines cannot be evacuated.	Depending on the size of the pump, these lines are often already defective or broken down when the pump is installed.	NONE!!! Even under difficult operating conditions, the pump works impeccably.

**Protection of system processes** *To protect the overall system from process interruptions, it might be necessary all the same to have a „lack of fluid“ indicated so that appropriate measures can be taken immediately. Therefore, we recommend installing an additional electronic pump protection device. These protectors are available in various designs.*

**Our product specialists will be glad to help you. Please take contact to your personal adviser – by e-mail or phone**

**+49 22 03/93 94 0**

**trockenlaufsicherheit@sondermann-pumpen.de**

SONDERMANN  
PUMPEN + FILTER GMBH & CO. KG  
August-Horch-Straße 4, D-51149 Köln  
Phone +49 22 03/93 94-0  
Fax +49 22 03/93 94-48  
info@sondermann-pumpen.de

[www.sondermann-pumpen.de](http://www.sondermann-pumpen.de)

