

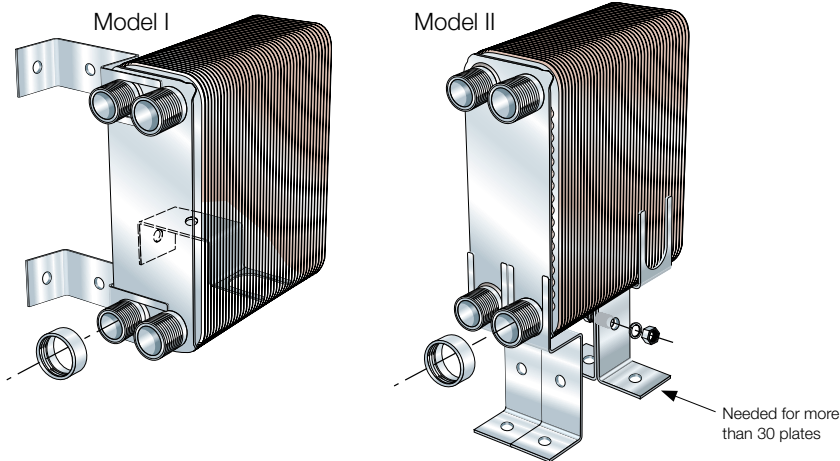

Feet and brackets

For brazed and fusion-bonded heat exchangers

Floor and wall support brackets



CB27, CB52, AlfaNova 27 and 52

Model	No. of plates	Part number	Quantity
I	0-30	162965401	1
II	31-150	162965402	1
		162965401	1

Material: Galvanized steel

CB76, CB77 and AlfaNova 76

Model	No. of plates	Part number	Quantity
I	0-30	162965501	1
II	31-150	162965502	1
		162965501	1

Material: Galvanized steel

NB! These brackets can only be used with;

162965401 & 162965402: 1" ISO 228/1-G, 45 mm length (V22)
162965501 & 162965502: 2" ISO 228/1-G, 48 mm length (B23)

Rigid foot

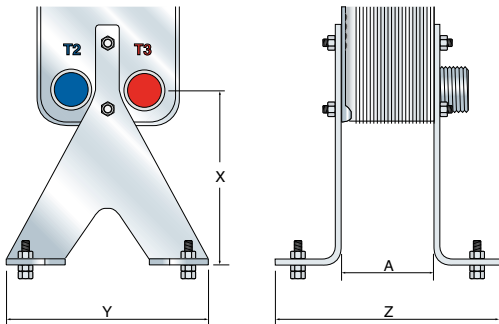

Unit	X	Y	Z	Feet mounted	Part number
CB76/CB77	199	260	A+180	option	3456108301
AlfaNova 76	199	260	A+180	option ^{*)}	3456108301
CB100	199	260	A+180	option <100 plates yes >100 plates	3456166901
CB200/CBH200	178	400	A+160	yes	incl. in heat exchanger
CB300	217 (S2)/194.5 (S3)	466	A+260	yes	incl. in heat exchanger
AlfaNova 400	242	466	A+260	yes	incl. in heat exchanger

Material: Galvanized steel

Option: Can be equipped with feet if stud bolts have been welded on the unit.

All measurements are in mm.

^{*)} AlfaNova 76 is manufactured with stud bolts.

Adjustable foot

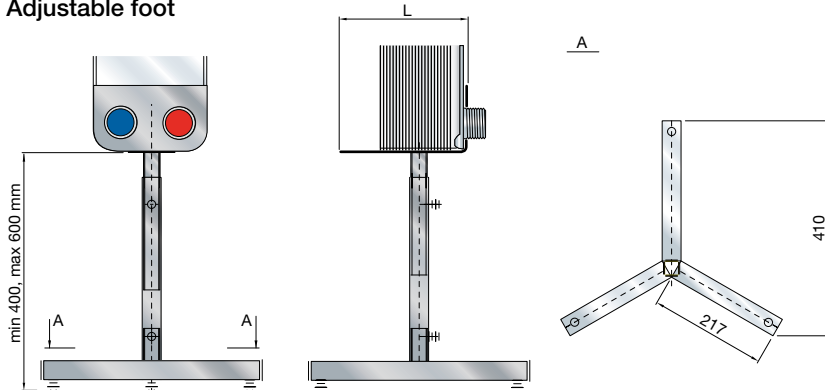

CB27, CB52, AlfaNova 27 and 52

No. of plates	L	Part number
10-60	45	3456089801
61-100	130	3456089802
101-150	200	3456089803

Material: Steel painted black

NB! These brackets can be used with 1 1/4" thread or smaller.

CB76, CB77 and AlfaNova 76

No. of plates	L	Part number
10-60	190	3456090801
61-90	260	3456090804
91-120	350	3456090802
121-150	350	3456090803

Material: Steel painted black

NB! These brackets can be used with 2 1/2" thread or smaller.

How to contact Alfa Laval

Up-to-date Alfa Laval contact details for all countries are always available on our website at www.alfalaval.com.