



FLOW
LEVEL
PRESSURE
ANALYTICAL
TEMPERATURE
INSTRUMENTATION
PASTEURIZATION CONTROLS

omd 800-648-3326
oliver m. dean, inc. www.omdean.com

TF - Series "Smart" Pressure Transmitter

- *New options and mounting configurations for high temperature applications up to 400°F (204°C)*
- *Standard 4-20 mA output with "HART" protocol for digital communications*
- *Micro-based design provides best performance of any sanitary transmitter*
- *Widest choice of sanitary fittings*
- *Optional LCD display now available for vertical or horizontal viewing*
- *3-A compliant; Third party verified in accordance with standard 74-03*

The Anderson "T" series pressure transmitter is a microprocessor-based sensor specifically designed for sanitary fluid process applications in the Food and Beverage industry. This product provides an extremely high level of performance combined with the flexibility of digital communication via the "HART" protocol. The "T" series can be specified in several configurations including high temperature models that are available in direct or remote mount variations. The high temperature direct mount is also recommended for applications where a horizontal orientation is required for display viewing, such as tank tops and overhead lines. All models may be ordered with any of our wide variety of sanitary process fittings.

The "T" series simultaneously outputs an analog 4-20 mA signal while com-

municating digitally with a hand-held communicator or other "HART" host device. This allows configuration of parameters such as range, engineering units, tagging info, and other device specific information, from any accessible point in the output loop. The analog output can even be "trimmed" or calibrated while in service, if required. Also retained are internal, non-interactive zero and span analog adjustments. This provides the user with the immediate performance enhancements of this new product, with future compatibility with the "HART" protocol.

As with all Anderson sensors, the "T" series is designed to be cleaned and sterilized in place. The optional LCD display can be factory scaled to linear process engineering units, mA output, or 0-100%.



Complete Product Ordering Matrix

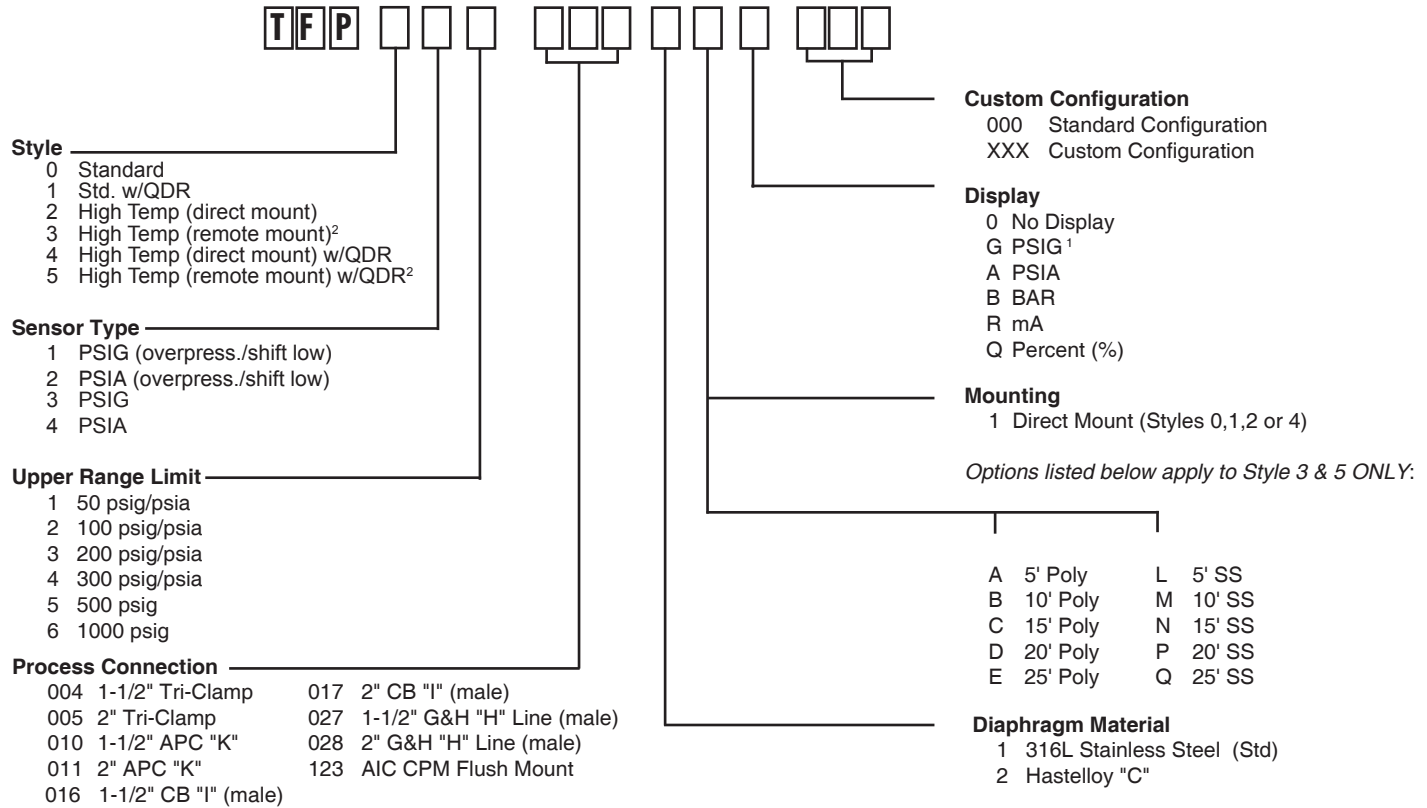

¹ Vacuum shown as (-) PSIG for compound ranges ² Pipe/Wall mount bracket included with remote mount option (Style 3 & 5)
 Compound Range Ordering Examples: For 30"-0-50 psig, select 50 psig URL
 For 30"-0-60 psig, select 100 psig URL

GENERAL SPECIFICATIONS

Ranges: Defined by Upper Range Limit (URL)
Rangeability (Turn-down): 10:1 via any HART Host Device
Over Pressure Limit: 2X URL
Over Pressure Output: Sensor Style 1 & 2: Above 110% of calibrated range - 3.8 mA
 Sensor Style 3 & 4: No specified over pressure output

Mechanical Trim Adjustments: Internally adjustable
 ±5% of span (zero); ±20% of span (span)

Output: 4-20mA, Two-wire, Linear, Digital Process variable superimposed on 4-20mA signal, available to any "HART" protocol conforming host

Power Supply: 13-40 Vdc
 18-45 Vdc with display

Indication: Optional, cap-mounted, LCD
 Indication accuracy ±1% F.S.

Temperature Limits (Process):
 Standard/Direct Mount: 0 to 275°F (-18 to 135°C)
 High Temp/Direct Mount: 0 to 350°F (-18 to 177°C)**
 High Temp/Remote Mount: 0 to 400°F (-18 to 204°C)**
 Temperature Limit (Ambient): 0 to 120°F (-18 to 49°C)
 Process Temperature Effect: Less than 0.2% of full scale output/10°F change

Standards: Designed and manufactured to sound engineering practices in accordance with Article 3.3 of the PED 97/23/EC

CE Compliance: Transmitter complies with all CE requirements.
 Optional LCD display accuracy = ±2% when subjected to a radiated transmission field of 150 to 180 MHz, and 230 to 350 MHz (field strength of 10V/m 80% AM 1KHz)

Performance Specifications:

Accuracy* (psig ranges): ±0.2% of URL
 (psia, compound vacuum): ±0.2% URL (above atmospheric zero); ±1.0% URL (below atmospheric zero)

***Accuracy includes repeatability, hysteresis and linearity**

Repeatability: ±0.06%
Hysteresis: ±0.07%
Linearity (BFSL): ±0.07%
 (±0.17% for psia, compound & vacuum ranges)

Stability: ±0.3% of URL/6 months

Physical Specifications:
 Wetted Material: 316L Stainless Steel, Hastelloy "C" optional
 Wetted Material Surface Finish: $R_{a,max} = 25$ microinches (.6 microns)

Housing Material: 304 Stainless Steel
Housing Ratings: NEMA 4X, IP-66
Electrical Connections: 1/2-14NPT conduit with screw terminals and integral test loops for HART interface

** Process vacuum in excess of 24" Hg may require slight de-rating of maximum temperature (consult factory)